

Comparing the performance of SVC and STATCOM for reactive power compensation in transmission lines

Amirreza Azizi^{1,*} and Erfan Paryab²

¹ Department of Electrical Engineering, Shahed University, Tehran, Iran: amirreza.azizi@shahed.ac.ir

² Department of Electrical Engineering, Amirkabir University Of Technology, Tehran, Iran: erfan.paryab@aut.ac.ir

* Corresponding Author

Received: 11/10/2023, Revised: 22/11/2023, Accepted: 27/11/2023.

Abstract

The stability of power systems is an important and vital challenge. The instabilities created in power networks are due to the existence of factors such as short circuit, switching, or error, which causes loss of generator synchronism and thus leads to interruption in the process of power generation. Today, by using FACTS tools and reactive power compensation, it helps to stabilize systems against such problems. In this paper, SVC and STATCOM are investigated and analyzed in order to maintain network synchronism and increase the dynamic stability and transient stability of the system against the mentioned factors, in reactive power compensation. The presented simulations were performed in the MATLAB/Simulink environment and the results were fully checked.

Keywords

Flexible Alternating Current Transmission Systems (FACTS), SVC, STATCOM, Reactive Power Compensation, Voltage Stability

1. Introduction

The electrical system is among the most important and basic parts of daily life. Therefore, the generation and transmission of electrical energy is one of the main tasks of electrical networks, and maintaining the reliability of energy distribution is one of the quality indicators of the supplier's resources. In recent years, due to the growth of power demand and the high cost of constructing power plants and transmission lines, power grids are sometimes operated close to the margin of their voltage stability, and therefore this form of stability has received much attention in recent years. Today, the largest share of power consumption in distribution networks goes to industrial loads such as fans, pumps, metal melting furnaces and such loads. Due to the relatively low power factor, these loads cause more reactive power to flow in the transmission and distribution lines. Lack of suitable control over reactive power leads to increased losses in feeders and also reduces the ability of lines to transmit active power. Due to the ever-increasing demand for energy and limitations in the structure of traditional networks, these networks are under increasing load pressure, and This issue causes voltage instability as well as errors and losses in system performance [1-5].

Voltage instability is one of the main challenges in the transmission network. In recent years, the issue of "grid stability" has become one of the most important challenge in power generation and transmission lines. Any imbalance in energy distribution due to disturbances can make the system unstable. The main reason for voltage instability is the inability of the power system to

supply the required reactive power. For this reason, reactive power compensation in power networks in order to prevent voltage collapse and reduce losses is an important issue that can be investigated. As a result, to solve these challenges, the design of compensators is one of the important topics in the design of transmission lines. On the other hand, due to the existence of some limitations in AC transmission lines, the use of compensators can solve these limitations. The use of controllable compensators has a great impact on the quality of power distribution. One of the solutions to eliminate voltage instability in power grids is to provide reactive power in the suitable position. The use of power electronic devices can be a suitable answer to solve this challenge. By compensating for reactive power in the transmission network, power electronic tools eliminate system instability, voltage drops and fluctuations. Meanwhile, flexible alternating current transmission systems (FACTS) are a suitable solution for reactive power compensation in order to establish voltage stability [6-9].

In [1] with the aim of planning and controlling the reactive power of FACTS devices, investigations have been done by implementing a new algorithm in SVC (shunt) and thyristor controlled series compensator (TCSC). In the proposed method, the Whale Optimization Algorithm (WOA) shows its superiority in

this method by minimizing the reactive power loss and the total operating cost of the system including the cost of the real devices by maintaining the voltage profile within the permissible limit. The proposed algorithm is an accurate and reliable method for the optimal coordination of facts devices compared to other sources of reactive power supply in the network. In [2], a new method of the SVC model developed with the thyristor firing angle law to improve the transient performance of frequency and voltage has been introduced and compared with the controlled thyristor static VAR compensators (CSVC) model. In reviewing the obtained results, the ESVC model performs better than the CSVC model because, in addition to only requiring local measurements without prior knowledge of the power system parameters, it directly calculates the law of the thyristor firing angle and applies the desired susceptance, and is also resistant in different operating conditions. Non-linear loads with the consumption of reactive power make the need to apply SVC in the transmission network inevitable. On the other hand, using SVC itself causes destructive harmonics in the lines. In order to solve this challenge, a method has been designed in [3] that limits these harmonics with the help of APF (active power filter). They are solved during reactive power compensation in SVC. Considering that the presence of APF in the SVC structure for medium voltages brings a lot of costs, in the next study, a new model called hybrid active power filter (HAPF) is designed for SVC, which provides a cost-effective method for compensation. heavy loads in medium voltage applications; Thus, when the HAPF is used to provide harmonic power as well as partial reactive power compensation, the SVC section provides and compensates the reactive power dynamically [4]. In [6], a new model has been presented to investigate the uncertainty in reactive power forecasting that can be compensated by SVC. The presented method tries to compare the traditional forecasting models of uncertainty analysis and the new probabilistic forecasting model. replace point-to-point prediction with optimal prediction intervals (PI). In this method, lower upper bound estimation (LUBE) is used to train Artificial Neural Network (ANN) to make high quality PI. A reactive power compensation technique with SVC compensator for a four-wire system is presented in [7], which, in addition to reactive power compensation, balances the load and also compensates the neutral current. In this technique, Δ -TCR structures with TSC-Y and Δ -TSC are combined. In this method, thyristor controlled reactor (TCR) is a thyristor-controlled reactor connected to Δ -shaped structure and a number of thyristor switch capacitors are connected to Δ and Y. In [8], to improve the quality of power in transmission lines, by combining an instantaneous compensator and SVC, a suitable and optimal design has been analyzed. Considering that the instantaneous compensator needs an independent power source, which itself imposes a lot of cost on the network, but in the new method, by combining it with SVC, it solves the decrease in the independent power capacity of the instantaneous compensator. In the final results, it was found that this combined method reduces the cost of creating a separate power supply to supply the compensation current and maintains the power factor. In

[9], a method has been investigated that investigates the reactive power consumption in wind turbines (WT). The induction generator consumes a lot of reactive power, so as a result, it causes fluctuation and imbalance in the output voltage for consumers. Therefore, SVC-WT can be used for power balancing. In this study, the power that is compensated by SVC static compensator is done with the help of neural network (NN) based model and using lower upper bound estimation (LUBE) method. In [10], with the aim of reducing light flicker (LF) in projects that use electric arc furnaces, a method for reactive power compensation based on optimized statcom has been proposed. Instability, harmonics, and voltage imbalance are among the main disadvantages of LF. In the proposed method, by modifying the classical algorithm that is based on the park transformation for statcom control by introducing a selective inter-harmonic filter, it enables the reactive power that is only between harmonics in a suitable band around the fundamental frequency that It mainly affects the LF to be compensated. In the next research, using the low voltage ride through (LVRT) strategy for cascaded h-bridge (CHB)-Statcom operation, the operator can control the reactive power of positive and negative sequences in the condition that the network is unbalanced, and other degrees of CHB Statcom for Apply capacitor voltage balancing. In this method, balancing is achieved by a combination of zero sequence voltage injection and negative sequence active current control [11]. In [12], an operational strategy is proposed under the title of analyzing the use of PWM in emergency situations to prevent overcurrent and the occurrence of fluctuations and power outages, in which during the recovery of faults such as line-to-ground (LG), line-to-line (LL) and three-phase fault, this scenario is exploited. This strategy provides system reactive power to prevent SVC overcurrent, which brings high efficiency when power system faults and disturbances occur. In [13], a comparison has been made between svc and statcom in order to compensate the reactive power of a wind farm connected to the grid. According to the results, it can be seen that statcom produces more reactive power in addition to having the same compensation capacity. From an economic point of view, due to the fact that the compensation capacity is reduced in statcom, it is more economical for investment than svc. In [14], a comparison is made between Double-Star Chopper Cell (DSCC) and Single-Delta Bridge Cell (SDBC) topology multi-level converters for statcom. According to the tests, we see that SDBC topology requires less energy storage than to DSCC. Less power loss was observed during positive sequence compensation and sdbc losses increased during negative sequence execution, as a result of which dsc has shown better performance. In [16], the performance and characteristics of power switches in the transmission network have been investigated. In the investigation, it is clear that the series compensation and hvdc loading level do not have much effect on the oscillation frequency as well as the magnitude of the oscillation, so that the effect of the number of standby statcoms is greater than other available factors. Also, in an AC network that is weakened by instabilities The use of several statcoms in the connected state causes instability and has a high effect on increasing the effective short circuit ratio

(ESCR), reducing the oscillation frequency, and improving the damping. In statcom, in addition to the power operating modes, there is an adaptive compensation operation mode that has the ability to compensate for the voltage imbalance, which is mentioned in the research [17].) is done sporadically in network connected mode and the used synchronous machine model is described as s-statcom with the concept of derived vectors that leads to a model in the (alpha and beta) framework.

2. FACTS DEVICES

In an ideal power system network, the voltage should be in its balanced state and the amplitude and phase of the voltage should be 120 degrees different. The network current may be unbalanced and disturbed and make the network unstable. One of the most important reasons for imbalance in a transmission system is the non-uniformity of single-phase loads such as frictional single-phase networks, rural networks and loads that cause partial imbalance and mild instability is transmitted in the network. On the other hand, the occurrence of imbalance and large short-term instabilities can occur due to power system errors such as single-phase to ground error, three-phase connection, etc. The occurrence of unbalanced voltage in the network can cause an increase in losses in the power transmission network and inappropriate performance of power electronics converters and induction drivers. Accordingly, the issue of reactive power control is raised, because reactive power control is one of the basic factors in increasing stability and improving power quality in power systems; In such a way that the lack of supply of sufficient amount and the lack of a suitable control method of re-active power causes an increase in transmission losses, a decrease in power transfer capability, and a decrease in voltage regulation at the end of the lines and at the load location [18-22].

Currently, various types of FACTS devices are used in power transmission networks, the most important of which are:

- SVC: Static Var compensator
- TCSC: thyristor control series capacitor
- STATCOM: static compensator

In the past, most of the reactor controlled with TCR thyristor and switched capacitor with TCSC thyristor were used for reactive power compensation. But nowadays, SVC and STATCOM are used as one of the newest generations of the second generation of FACTS devices with suitable dynamic performance, and in this research, the investigation and comparison of these two compensators in power transmission lines has been done.

2.1. Static Var Compensator (SVC)

SVC is one of the most important elements of FACTS, which has been used for many years due to its technical and economic advantage in solving the problem of voltage dynamics. The accuracy, accessibility and fast response of SVC compared to classical parallel compensators make it a very efficient device in controlling the transient and mode voltages. The figure

below shows the structure of SVC and its I-V characteristic.

SVC is connected in parallel to the network and as shown in the figure, it can appear in two modes of reactive power compensation in the form of inductance or capacitance. In the capacitive current greater than I_{Cmax} , the SVC becomes a capacitor and its reactive power changes as a function of the grid voltage. The slope of the $V-I$ graph between I_{Cmax} and I_{rmax} is usually considered to be 2% to 5%.

One of the most important applications and advantages of using SVC in the transmission network can be mentioned: stabilizing voltage in weak networks, reducing transmission losses, increasing power transmission capacity, increasing damping of small disturbances, improving voltage stability and eliminating power fluctuations. SVCs are divided into different types according to the elements used in their construction, the most common of which are: TCR thyristor control reactor, TSC thyristor switch capacitor, TSR thyristor switch reactor and MSC mechanical switch capacitor, which are usually used for their installation Points in the vicinity of major and large loads (wide urban areas), near voltage-sensitive loads or in the vicinity of industrial loads are suggested. In fact, the installation of SVC in these three places has the greatest impact on power network loads. As mentioned earlier, if the SVC approaches its reactive power limit, it becomes a fixed capacitor and its reactive power generation becomes a function of the network voltage. This phenomenon is considered one of the disadvantages of SVC.

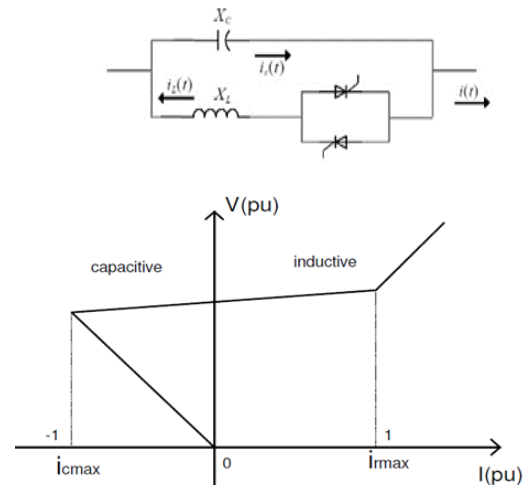

Fig. 1 SVC structure and its V_I characteristic.

2.2. Static Var Compensator (SVC)

Static compensators or statcom are connected in parallel to the network and have the ability to inject and absorb reactive load. statcom (static synchronous reactive power compensator) is one of the important FACTS tools that plays an effective role in voltage stability. The main role of STATCOM is actually voltage support at critical points.

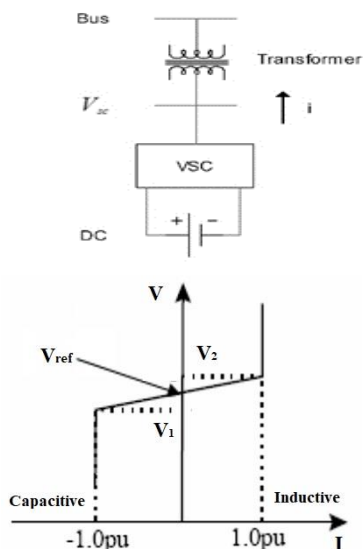

Fig. 2 STATCOM and its V_I characteristic.

The basis of operation of STATCOM is similar to synchronous condenser. Since power electronics are used in the construction of this device, it is called a static compensator. The converters used in this compensator provide the required reactive power locally at the connection point of the STATCOM to the network and its output can be continuously adjusted, for this reason in cases where the power network voltage has wide changes (in the event of a disturbance or after fixing error) this compensator is used. Figure (2-3) shows a diagram of STATCOM and its V_I characteristic. Generation or absorption of reactive power is done by the voltage source converter (VSC) by adjusting the V_{ref} voltage.

Table 1. Comparison of V_I characteristic of SVC and STATCOM [3] and [2].

feature	STATCOM	SVC
Characteristic V_I	Current source with good performance in low voltage conditions	Impedance with proper performance in
Control range	symmetrical	High voltage conditions
response time	1 to 2 cycles	Adjustable in any range of CR/TSR/TSC branches
required space	40-50% compared to SVC	1 to 3 cycles
Accessibility	98-96%	100%
Investment cost	120-150%	more than 99%

According to the structure of STATCOM, one of its most important applications can be mentioned: dynamic voltage control, improvement of transient stability, elimination of power fluctuations in the transmission

network and control of real and reactive power. There are various methods for extracting the reference current in STATCOM, one of these methods is the reactive power theory is instantaneous. This theory can be used in other compensators, such as active filters. This theory was proposed for the first time by Akagi and is also known as instantaneous reactive power theory, instantaneous power theory or p-q theory. The basis of this theory is based on the conversion of the three-phase to two-phase quantity in the $\alpha - \beta$ device and the calculation of instantaneous active and reactive powers.

3. COMPARISON OF STATCOM AND SVC:

STATCOM and SVC are very similar in terms of compensation functionality, but their working principles are fundamentally different. The STATCOM acts as a synchronous voltage source, while the SVC acts as a controlled reactive admittance. This difference makes the STATCOM have better performance characteristics and more flexibility than the SVC. Figure 4-2 compares STATCOM and SVC voltage-current specifications. As can be seen from the figure, in the linear performance range of V-I characteristic, the compensation performance of STATCOM and SVC is similar. By

considering the non-linear performance range, the STATCOM is able to control its output current within the maximum capacitive and self-compensation range independently of the system's AC voltage. While the maximum compensation current that can be obtained using SVC decreases linearly with the system voltage. Therefore, in supplying voltage under large system disturbances during which the system voltage is out of the linear range, STATCOM works much more effectively than SVC. STATCOM's ability to maintain full capacitor output current in low system voltage conditions makes STATCOM more effective than SVC in maintaining system transient stability. When active power compensation is needed, STATCOM is able to take power from an energy storage source (battery, capacitor bank, etc.) using its DC terminal and inject it into the network from its AC terminal. While SVC does not have this capability.

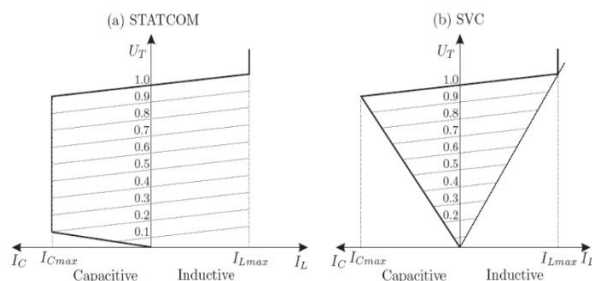

Fig. 3. Comparison of V_I characteristic of SVC and STATCOM

In dealing with a lot of uncertainties, the performance and efficiency of type-1 fuzzy systems is not suitable. The membership degree of type-1 fuzzy sets is a crisp number while the membership degree of type-2 fuzzy sets is a type-1 fuzzy number.

4. COMPARISON OF STATCOM AND SVC:

4. 1. SVC simulation

SVC is a parallel reactive power compensator that includes TSC and TCR as shown in the figure below. The stability and control equations of the system are performed by the linearized models of the power network.

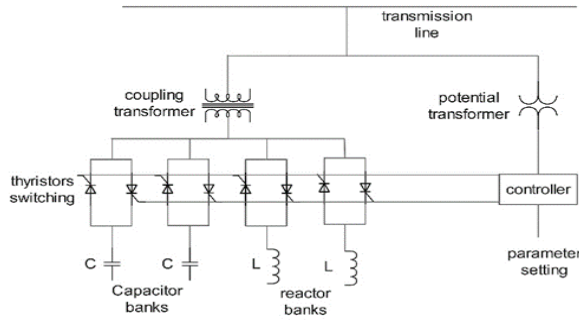

Fig. 4. SVC structure [4]

Figure 4 shows a single machine model with an infinite bus. This system can be described by nonlinear differential equations from the Heffron-Phillips linear model which is given below.

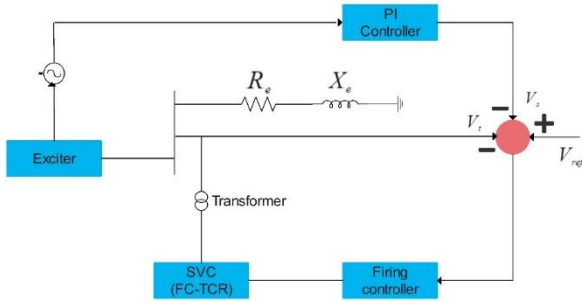

Fig. 5. single machine to infinite bus model with SVC.

In the following section, the network equations without the presence of SVC are placed:

$$\dot{\delta} = \omega_0 \Delta\omega \quad (1)$$

$$\Delta\dot{\omega} = \frac{(P_m - P_e - D\Delta\omega)}{2H} \quad (2)$$

$$\dot{E}'_q = \frac{(-E'_q - E_{qe})}{T'_{do}} \quad (3)$$

$$E_{qe} = K_A \frac{(V_{t0} - V_t)}{1 + sT_A} \quad (4)$$

$$P_e = \frac{E'_q V_b \sin \delta}{X'_{d\Sigma}} - \frac{V_b^2 (X_d - X'_d) \sin 2\delta}{2X'_{d\Sigma} X_{q\Sigma}} \quad (5)$$

$$E_q = \frac{X_{d\Sigma} E'_q}{X'_{d\Sigma}} - \frac{(X_d - X'_d) V_b \cos \delta}{X'_{d\Sigma}} \quad (6)$$

$$V_{td} = \frac{X_q V_b \sin \delta}{X_{d\Sigma}} \quad (7)$$

$$V_{tq} = \frac{X_L E'_q}{X'_{d\Sigma}} + \frac{V_b X'_d \cos \delta}{X'_{d\Sigma}} \quad (8)$$

$$X'_{d\Sigma} = X'_d + X_L \quad (9)$$

$$X_{d\Sigma} = X_q + X_L \quad (10)$$

$$X_{d\Sigma} = X_d + X_L \quad (11)$$

When an SVC is installed in the system, the above equations should be changed and the effect of the installed SVC with “XSVC” reactance on the performance of the whole system should be seen. The equations with SVC are expressed as follows:

$$C = 1 - \frac{X_L}{X_{SVC}} \quad (12)$$

$$X_{TL} = \frac{X_L}{C} = \frac{X_L}{1 - \frac{X_L}{X_{SVC}}} \quad (13)$$

$$P_e = \frac{E'_q V_b \sin \delta}{C X'_{d\Sigma}} - \frac{V_b^2 (X_d - X'_d) \sin 2\delta}{2C^2 X'_{d\Sigma} X_{q\Sigma}} \quad (14)$$

$$E_q = \frac{X_{d\Sigma} E'_q}{X'_{d\Sigma}} - \frac{(X_d - X'_d) V_b \cos \delta}{C X'_{d\Sigma}} \quad (15)$$

$$V_{td} = \frac{X_q V_b \sin \delta}{C X_{d\Sigma}} \quad (16)$$

$$V_{tq} = \frac{X_L E'_q}{X'_{d\Sigma}} + \frac{V_b X'_d \cos \delta}{C X'_{d\Sigma}} \quad (17)$$

By linearizing the above equations in operating conditions, the linearized Heffron-Phillips model of the system with SVC can be obtained from the following figure.

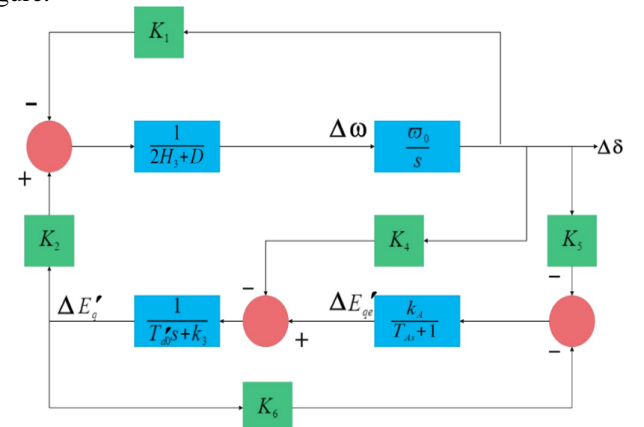

Fig. 6. block diagram of single machine control to infinite bus without SVC [3].

When the SVC is connected to the infinite bus, its control system is initially determined. Although there are many effective control patterns for the operation of this compensator, only one PI controller is selected for it. The

$$\dot{V}_{dc} = \frac{VI}{C V_{dc}} \cos(\delta - \theta) - \frac{G_c}{C} V_{dc} - \frac{R}{C} \frac{I^2}{V_{dc}} \quad (20)$$

$$0 = \begin{bmatrix} P - VI \cos(\delta - \theta) \\ Q - VI \sin(\delta - \theta) \\ P - V^2 G + k V_{dc} V G \cos(\delta - \alpha) + k V_{dc} V B \sin(\delta - \alpha) \\ Q + V^2 B - k V_{dc} V B \cos(\delta - \alpha) + k V_{dc} V G \sin(\delta - \alpha) \end{bmatrix} \quad (21)$$

When admittance:

$$(R + jX)^{-1} = G + jB \quad (22)$$

As an indicator of the impedance of the transformer and each filter series Ac. Gc is used to model the switching inertia of the converter, which is caused by the electronic switches and its circuits, which has a direct effect on the dynamics of the capacitor voltage .

$$k = \sqrt{\frac{3}{8m}} \quad (23)$$

K Is directly proportional to the modulation index (m). The variables xc and (0) Fc in the above equation are the variables of the internal control system and the equations, respectively, and hence have a great dependence on the PWM or phase control method used in the control system. In the simple voltage controller shown in the figure below, variables and differential equations are directly related to different control blocks. It can be seen that in this PWM controller, the AC bus voltage range is controlled through the modulation index m and this has a direct effect on the VSC voltage range. Although the phase angle a which basically determines the active power flow p in the controller and the charge and discharge of the capacitor are used to directly control the DC voltage range.

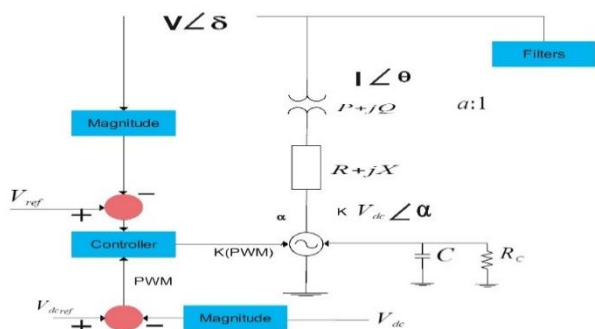

Fig. 32. PWM voltage control of a STATCOM.

The steady state model can be easily obtained from the previous equation by substituting the corresponding differential equations with the DC voltage steady state equations and the STATCOM voltage control characteristics.

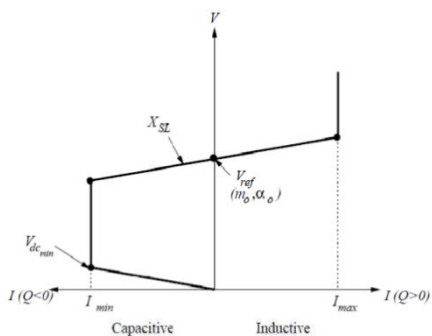

Fig. 43. STATCOM performance diagram in permanent mode.

In the circuit designed for simulation, the number of 6 thyristors is included. PWM applies two sine and triangular waves to the circuit. Triangular wave is a carrier wave whose frequency is much higher than sine wave. In order to be able to apply PWM, we act in such a way that a scenario is made for a comparison between two types of applied waves. If the size of the sine wave is greater than the triangular wave, the ON command is issued, and if the triangular wave is greater than the sine wave, the cut command is issued. For this purpose, we use angles. On the other hand, for the angle of fire, calculations have been done through a control circuit along with a lead-lag filter and a PI controller. In this study, the output of the PI controller is the angle in radians, which can be converted to degrees. Now, by subtracting 2 obtained sets, 6 angles can be obtained. To check the on/off mode, a triangular wave is made exactly with the PLL block and the 6 fire angles obtained. First, we multiply these angles by the carrier frequency by 33 and create a model of it along 360 degrees. The simulation circuit and the results of the simulation are shown in the figure below. The simulated scheme shows the steady state and dynamic performance of a STATCOM that regulates the voltage in a 500KV system with a frequency of 60HZ and 100MVA.

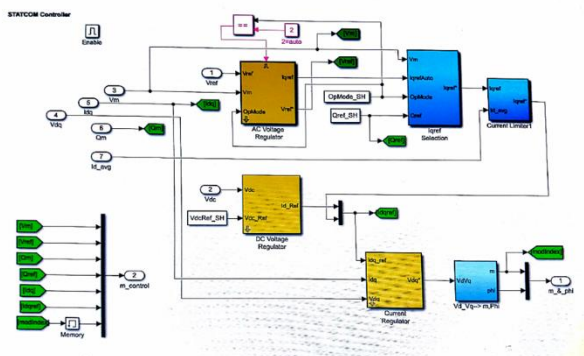

Fig. 54. STATCOM simulation circuit

In the control system designed for statcom in the simulations, a phase locking loop (PLL) that coincides with the positive sequence component of the three-phase primary voltage v1. The PLL output (phi angle) is used to calculate the vertical and direct axis components of three-phase AC voltages and currents (labeled Vd, Vq, Id, Iq in the simulation file). The measuring system that measures the d, q components of AC positive sequence voltages and currents, which must be controlled along with DC voltage (Vdc). An external regulation loop that includes an AC voltage regulator and a DC voltage regulator is considered. The output of the AC voltage regulator is the reference current Iqref for the current regulator (Iq = current perpendicular to the voltage that controls the passing reactive power). The output of the DC voltage regulator is the reference current Idref for the current regulator (Id = current in phase with the voltage that controls the active power). In an internal current regulation loop that includes a current regulator, the current regulator adjusts the amplitude and phase of the voltage generated by the PWM converter (V2d, V2q in the simulation circuit) from the reference

currents I_{dref} and I_{qref} , respectively, by the AC voltage regulators. Controls the DC generated.

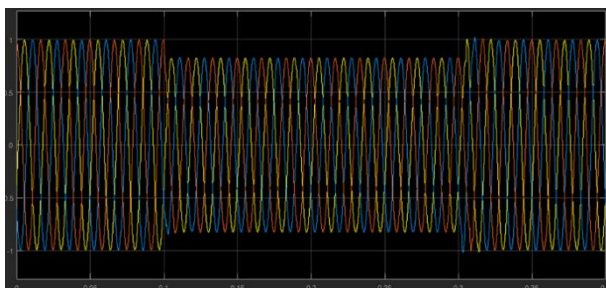

Fig. 65. network voltage before compensation

Figure 15 shows the network voltage. As shown, as a result of load change in time 0.1 to 0.3, the network voltage has decreased and the network has moved away from its stable state.

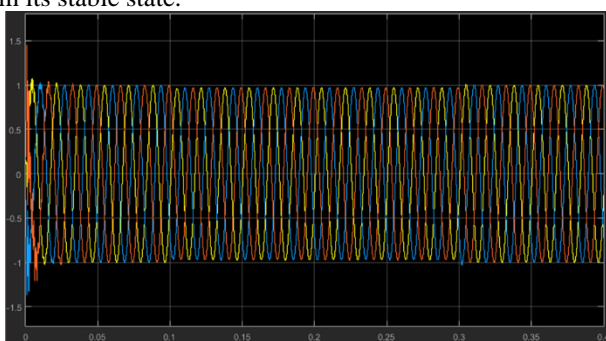

Fig. 76. network voltage after compensation

In figure 16 the network voltage after compensation is shown, it can be seen that after the compensation operation, the network voltage remained at its constant value when under load, and the effect of the presence of STATCOM is fully shown and full compensation There have been.

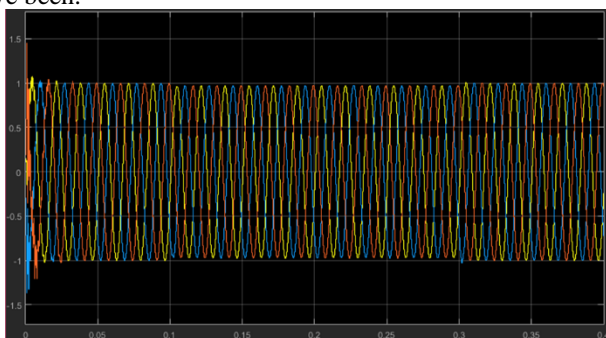

Fig. 87. injected current by STATCOM

The above figure shows the reference voltage and the measured voltage of the network, which is under load in time 0.1 to time 0.3 and the network voltage decreases significantly.

The above figure shows the reference voltage and the measured voltage of the network, which is under load in time 0.1 to time 0.3 and the network voltage decreases significantly.

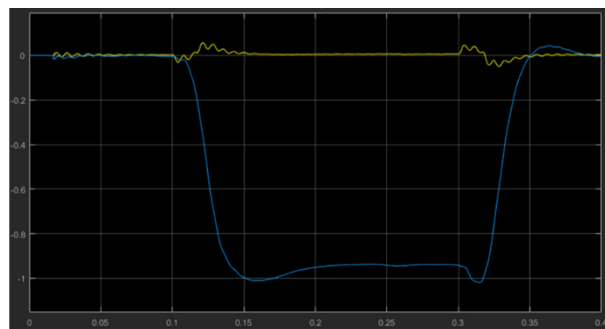

Fig. 98. diagram of active power and reactive power of the network

Figure 18 shows the active and reactive powers of the network, which is under load in time 0.1 to 0.3, and we see a decrease in the reactive power of the network, and compensation must be done to solve this problem .

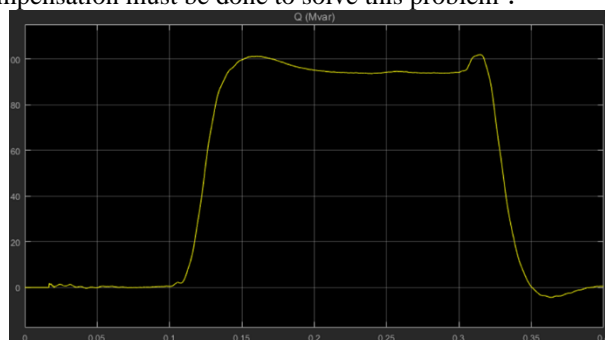

Fig. 109. Reactive power injected by the compensator

In this diagram, the reactive power that STATCOM injects into the network can be seen. In figure 18, it was observed that the lack of reactive power is determined at the time 0.1 to 0.3 when the network is under load. But in figure 19 we can see that in time 0.1 to 0.3 the compensator performs the compensation action which is the injection of reactive power into the network and solves the problem of lack of reactive power well.

5. Conclusion

STATCOM and SVC are very similar in terms of compensation functionality, but their operating principles are fundamentally different. The STATCOM acts as a synchronous voltage source, while the SVC acts as a controlled reactive admittance. This difference makes STATCOM have better performance characteristics and more flexibility than SVC. As you know, in the linear performance range of V-I characteristic, the compensation performance of STATCOM and SVC is similar. Considering the non-linear performance range, STATCOM is able to control its output current in the range of maximum capacitive and inductive compensation independent of the AC system voltage. While the maximum compensation current that can be obtained using SVC decreases linearly with the system voltage. Therefore, in providing voltage under large system disturbances during which the system voltage is out of the linear range, STATCOM works much more effectively than SVC. The ability of STATCOM to fully maintain the capacitor output current in low system voltage conditions makes STATCOM more effective than SVC in maintaining the transient

stability of the system. When active power compensation is needed, STATCOM is able to take power from an energy storage source (battery, capacitor bank, etc.) using its DC terminal and inject it into the network from its AC terminal. While SVC does not have this capability.

References

- [1] Chankaya, M.; Hussain, I.; Malik, H.; Ahmad, A.; Alotaibi, M.A.; Márquez, F.P.G. Seamless Capable PV Power Generation System without Battery Storage for Rural Residential Load. *Electronics* 2022, 11, 2413. <https://doi.org/10.3390/electronics11152413>
- [2] Krishna, G.; Singh, R.; Gehlot, A.; Akram, S.V.; Priyadarshi, N.; Twala, B. Digital Technology Implementation in Battery-Management Systems for Sustainable Energy Storage: Review, Challenges, and Recommendations. *Electronics* 2022, 11, 2695. <https://doi.org/10.3390/electronics11172695>
- [3] Iranmehr H, Aazami R, Tavooosi J, Shirkhani M, Azizi AR, Mohammadzadeh A, Mosavi AH, Guo W. Modeling the Price of Emergency Power Transmission Lines in the Reserve Market Due to the Influence of Renewable Energies. *FRONTIERS IN ENERGY RESEARCH*. 2022 Jan 13;9.
- [4] Tavooosi J, Shirkhani M, Azizi A. Control engineering solutions during epidemics: A review. *International Journal of Modelling, Identification and Control*. 2021;39(2):97-106.
- [5] Tavooosi J, Shirkhani M, Azizi A, Din SU, Mohammadzadeh A, Mobayen S. A hybrid approach for fault location in power distributed networks: Impedance-based and machine learning technique. *Electric Power Systems Research*. 2022 Sep 1;210:108073.
- [6] Raj, S.; Bhattacharyya B. Optimal placement of TCSC and SVC for reactive power planning using Whale optimization algorithm. *Swarm and Evolutionary Computation* 2018,40,131-43.
- [7] Wan, Y. Extended SVC modeling for frequency regulation. *IEEE Transactions on Power Delivery* 2020,36,484-7.
- [8] Wang, L.; Lam, C.S.; Wong, M.C. Hybrid structure of static var compensator and hybrid active power filter (SVC//HAPF) for medium-voltage heavy loads compensation. *IEEE Transactions on Industrial Electronics* 2017,65,4432-42.
- [9] Chakraborty, S.; Mukhopadhyay, S.; Biswas, SK. Coordination of D-STATCOM & SVC for Dynamic VAR Compensation and Voltage Stabilization of an AC Grid Interconnected to a DC Microgrid. *IEEE Transactions on Industry Applications* 2021,58,634-44.
- [10] Kavousi-Fard, A.; Khosravi, A.; Nahavandi, S. Reactive power compensation in electric arc furnaces using prediction intervals. *IEEE Transactions on Industrial Electronics* 2017,64,5295-304.
- [11] Das, S.; Chatterjee, D.; Goswami, SK. A reactive power compensation scheme for unbalanced four-wire system using virtual Y-TCR model. *IEEE transactions on industrial electronics* 2017,65,3210-9.
- [12] Liu, Y.W.; Rau, S.H.; Wu, C.J.; Lee, W.J. Improvement of power quality by using advanced reactive power compensation. *IEEE Transactions on Industry Applications* 2017,54,18-24.
- [13] Wang, Z.; Zhang, B.; Mobtahej, M.; Baziar, A.; Khan, B. Advanced reactive power compensation of wind power plant using PMU data. *IEEE Access* 2021,9,67006-14.
- [14] Feola L, Langella R, Papič I, Testa A. Selective interharmonic compensation to improve statcom performance for light flicker mitigation. *IEEE Transactions on Power Delivery* 2018,33,2442-51.
- [15] Neyshabouri Y, Chaudhary SK, Teodorescu R, Sajadi R, Iman-Eini H. Improving the reactive current compensation capability of cascaded H-bridge based STATCOM under unbalanced grid voltage. *IEEE Journal of Emerging and Selected Topics in Power Electronics* 2019,8,1466-76.
- [16] Qi, J.; Zhao, W.; Bian, X. Comparative study of SVC and STATCOM reactive power compensation for prosumer microgrids with DFIG-based wind farm integration. *IEEE Access* 2020,8,209878-85.
- [17] Cupertino, AF.; Farias, JVM, Pereira HA, Seleme SI, Teodorescu, R. Comparison of DSCC and SDBC modular multilevel converters for STATCOM application during negative sequence compensation. *IEEE Transactions on Industrial Electronics* 2018,66,2302-12.
- [18] Shu D, Xie X, Rao H, Gao X, Jiang Q, Huang Y. Sub-and super-synchronous interactions between STATCOMs and weak AC/DC transmissions with series compensations. *IEEE Transactions on Power Electronics* 2017,33,7424-37.
- [19] do Nascimento Gomes, L.; Abrantes-Ferreira, AJG.; da Silva Dias, RF.; Rolim, LGB. Synchronverter-

based STATCOM with voltage imbalance compensation functionality. IEEE Transactions on Industrial Electronics 2021,69,4836-44.

[20] Sang, Y; Sahraei-Ardakani, M. The interdependence between transmission switching and variable-impedance series FACTS devices. IEEE Transactions on Power Systems 2017,33,2792-803.

[21] Panfilov, D.; ElGebaly, AE.; Astashev, M.; Rozhkov, AN.; editors. Control system operation in thyristors switched SVCs with improved quality of reactive power. 2018 IEEE International Conference on Environment and Electrical Engineering and 2018 IEEE Industrial and Commercial Power Systems Europe (EEEIC/I&CPS Europe) 2018: IEEE.