

Machine Learning-based Flexible Link Robot Control

Ali Abdali ^{1,*} and Verya Monjezi ²

¹ Control Systems and Instrumentation Department of Iranian Offshore Oil Company, Kharg, Bushehr 7546143572, Iran

² Computer Science Department, University of Texas at El Paso, TX79968, USA

E-mail addresses: ali.ebdali@gmail.com ; vmonjezi@miners.utep.edu

*Corresponding author

Received: 2023/08/03, Revised: 2023/08/30, Accepted: 2023/09/02.

Abstract

Fuzzy systems have recently attracted the attention of researchers and various methods based on fuzzy logic systems have been presented. This paper presents a novel adaptive neuro fuzzy inference system based on interval Gaussian type-2 fuzzy sets in the antecedent part and Gaussian type-1 fuzzy sets as coefficients of linear combination of input variables in the consequent part. The capability of the proposed ANFIS2 for function approximation and dynamical system identification is remarkable. The structure of ANFIS2 is very similar to ANFIS but in ANFIS2 a layer is added for purpose to type reduction. An adaptive learning rate-based backpropagation with convergence guaranteed is used for parameter learning. Finally, the proposed ANFIS2 are used to control of a flexible link robot arm. Simulation results shows the proposed ANFIS2 with Gaussian type-1 fuzzy set as coefficients of linear combination of input variables in the consequent part has good performance and high accuracy but more training time.

Keywords

ANFIS, Interval Type-2 Fuzzy Sets, Inverse Control, Flexible Link Robot.

1. Introduction

High computation ability, adaptability and parallel processing are the important advantages of neural networks [1-5]. Using the knowledge of expert man as if-then rules and having real concept of parameters are the advantages of fuzzy systems. Among hybrid fuzzy neural networks, ANFIS is very popular and widespread. ANFIS is very simple and intelligible so it has affected many areas such as geography, medical Sciences, meteorological science, chemical and petroleum engineering and etc. [6-8]. A flexible link arm is a distributed parameter system of infinite order, but must be approximated by a lower-order model and controlled by a finite-order controller due to onboard computer limitations, sensor inaccuracy, and system noise. The so-called “control spillover” and “observation spillover” effects then occur, which under certain conditions can lead to instability [9,10].

In recent ten years, type-2 fuzzy logic with more capabilities and more flexibility than type-1 fuzzy logic has been investigated. Castillo et al. investigated type-2 fuzzy logic in more details [11]. Huang and Chen [12] used the combination of quantum inspired bacterial foraging algorithm (QBFA) and recursive least squares (RLS) to tune a type-2 fuzzy system. Tavooosi et al. proposed a different architecture of interval type-2 takagi-sugeno-kang fuzzy neural network [13-15]. They proposed an ANFIS based on type-2 fuzzy sets. Shahnazi [16] used type-2 fuzzy systems to approximate the unknown nonlinearities in MIMO systems control problem. He derived all the adaptive laws via Lyapunov synthesis approach.

Not much study has been done on fuzzy systems with type-1 (or type-2) fuzzy sets in the consequent part. In most of papers the consequent part is singleton [17] or interval type-1 fuzzy sets [18-20] up to now. In continue some of the works in this area are reviewed. In [21] interval type-2 fuzzy integrators in ensembles of ANFIS models for the time series prediction is used. Genetic algorithm is used to optimize of the proposed model. The equations of Type-2 ANFIS and its optimization are not presented. In [22] interval type-2 adaptive network-based fuzzy inference system with type-2 non-singleton fuzzification have introduced. Interval type-1 fuzzy sets have been used as consequent parameters. Mendez and Hernandez [23] presented a type-2 fuzzy ANFIS that interval type-1 non-singleton fuzzy numbers are the inputs and type-2 TSK FLS is the output and the consequent parameters are estimated by the recursive least-squares (RLS) method. They didn't provide further details of learning equations. Bhattacharyya et al. [24] proposed a type-2 fuzzy ANFIS that an interval type-2 fuzzy logic is used to combine the different outputs of the ANFIS classifiers to produce a final optimal result.

Tavooosi and Badamchizadeh proposed a type-2 Takagi-Sugeno-Kang fuzzy neural network with linear consequent part to system identification and modeling in [25]. Rule pruning was the novelty of that paper. Higher learning speed was the goal by reducing the parameter in both antecedent and consequent parts. Tavooosi et al. presented a new method to stability analysis of a class of type-2 fuzzy system in [26]. In [27], Jahangiri et al. proposed a method for stability analysis of a class of neural networks. In [28] a new method to MIMO type-2

fuzzy stability analysis has been presented. Robot manipulators have become increasingly important in the field of flexible automation. So, modeling and control of robots in automation will be very important. Some literatures used fuzzy logic to robot control [29-32].

This paper presents a novel ANFIS based on type-2 fuzzy named ANFIS2. The proposed method uses Interval Gaussian type-2 fuzzy sets in the antecedent part and Gaussian type-1 fuzzy sets as coefficients of linear combination of input variables in the consequent part. The paper is organized as follows. In section 2, type-2 fuzzy systems is viewed. In section 3, the structure of ANFIS2 is investigated. Parameter identification is given at the end of this section. In section 4, learning convergence of ANFIS2 based on lyapunov theory is derived. In section 5, the simulation studies are presented for identification of three nonlinear systems. Finally, Section 6 gives the conclusions of the advocated design methodology.

2. A Review on Type-2 Fuzzy Systems

In dealing with a lot of uncertainties, the performance and efficiency of type-1 fuzzy systems is not suitable. The membership degree of type-1 fuzzy sets is a crisp number while the membership degree of type-2 fuzzy sets is a type-1 fuzzy number.

Some difficulties of type-1 fuzzy logic can be solved by using type-2 fuzzy logic. In some systems such as time-series prediction, the exact membership degree is determined in a very difficult manner due to their complexity and their noisy information [33]. So, using type-2 fuzzy systems for describing behavior of these systems can be useful. In [34], some disadvantages of type-1 fuzzy sets are mentioned.

Fig. 1 shows the Gaussian primary membership function and Gaussian secondary membership function. For example, if $m = 0$, $\sigma = 1$ and $x = 1$ then degree of membership is 0.6, if this membership degree is too fuzzy or $\tilde{0.6}$ then primary membership is Gaussian type-1 fuzzy set with $m = 0$, $\sigma = 1$ and secondary membership is Gaussian type-1 fuzzy set with $m = 0.6$, $\sigma = 0.1$.

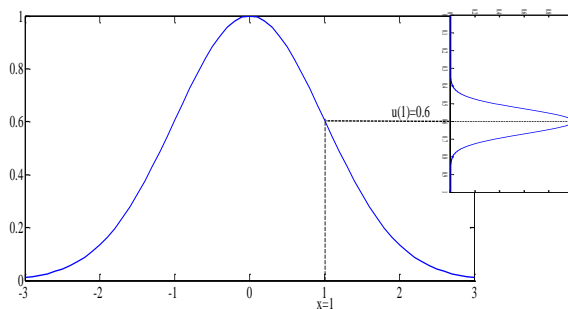

Fig. 1. Gaussian primary and secondary membership functions.

Note that, when secondary membership is not Gaussian type-1 fuzzy set and it is equal to one and in other words secondary membership function is interval set with one magnitude, then fuzzy set called interval type-2 fuzzy set.

Two cases of interval type-2 fuzzy sets are shown in Fig. 2. In Fig. 2-a, a case of a fuzzy set characterized by

a Gaussian membership function with mean m and a standard deviation that can take values in $[\sigma_1, \sigma_2]$ and in Fig. 2-b, a case of a fuzzy set with a Gaussian membership function with a fixed standard deviation σ , but an uncertain mean, taking values in $[m_1, m_2]$ and are shown.

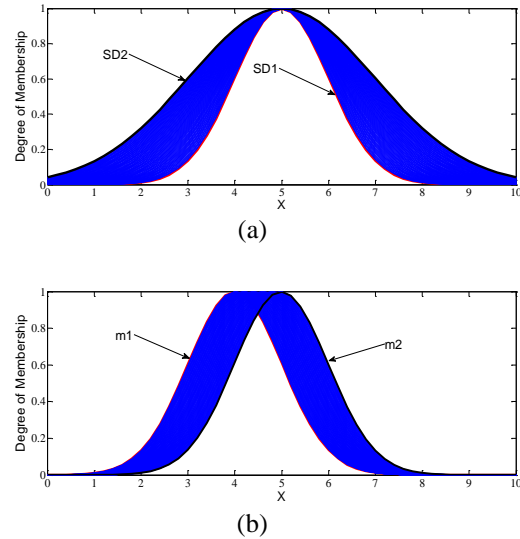

Fig. 2. a) Uncertainty in standard deviation b) uncertainty in mean.

In this paper Gaussian membership function with fixed standard deviation σ and uncertain mean is used (Fig. 2. b).

3. Adaptive Neuro Fuzzy Inference System by Type-2 Fuzzy Sets (ANFIS2)

Similar to type-1 TSK fuzzy systems, the output of type-2 TSK fuzzy systems is a function of their inputs. But in type-2 fuzzy systems the output and its coefficients are type-1 fuzzy sets. In this paper, the proposed ANFIS2 has seven layers that its structure is shown in Fig 3. The two rules of ANFIS2 can be described as follows:

$$R^1: \text{if } x_1 \text{ is } \tilde{A}_1 \text{ and } x_2 \text{ is } \tilde{B}_1 \text{ then } \tilde{y}_1 = \tilde{r}_1 + \tilde{p}_1 x_1 + \tilde{q}_1 x_2$$

$$R^2: \text{if } x_1 \text{ is } \tilde{A}_2 \text{ and } x_2 \text{ is } \tilde{B}_2^k \text{ then } \tilde{y}_2 = \tilde{r}_2 + \tilde{p}_2 x_1 + \tilde{q}_2 x_2 \quad (1)$$

Where $x_i (i = 1, 2)$ are inputs, $\tilde{y}_k (k = 1, 2)$ is output of the k th rule which it is type-1 fuzzy set (since it is a linear combination of Gaussian type-1 fuzzy sets), \tilde{A}_i^k are antecedent interval type-2 fuzzy sets, \tilde{r}_k , \tilde{p}_k and $\tilde{q}_k (k = 1, 2)$ are Gaussian type-1 fuzzy sets. For simplicity in description, we select only two inputs and two rules but the proposed ANFIS2 can be generalized to n -inputs and m -rules ($n, m \in N$).

The forward-propagation procedure is described as follows:

Layer 0: This layer is inputs layer. The number of nodes in this layer is equal to the number of inputs.

Layer 1: This layer is fuzzification layer. The output of this layer as follows:

$${}^1\mu_{k,i}(x_i, [\sigma_{k,i}, {}^1m_{k,i}]) = e^{-.5 \left(\frac{x_i - {}^1m_{k,i}}{\sigma_{k,i}} \right)^2} \quad (4)$$

$${}^2\mu_{k,i}(x_i, [\sigma_{k,i}, {}^2m_{k,i}]) = e^{-5\left(\frac{x_i - {}^2m_{k,i}}{\sigma_{k,i}}\right)^2} \quad (3)$$

Where $m_{k,i} \in [{}^1m_{k,i}, {}^2m_{k,i}]$ is uncertain mean for k th rule and i th input.

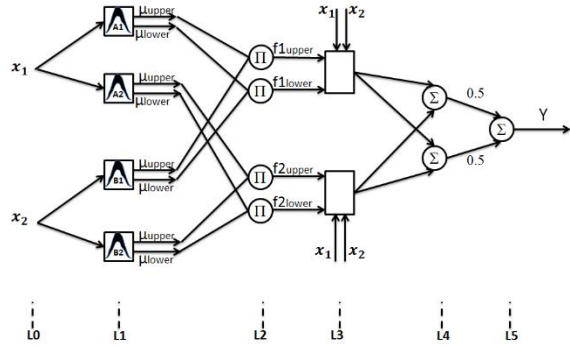

Fig. 3. The structure of ANFIS2.

$$\bar{\mu}_{k,i}(x_i) = \begin{cases} {}^1\mu_{k,i}(x_i, [\sigma_{k,i}, {}^1m_{k,i}]), & x_i < {}^1m_{k,i} \\ 1, & {}^1m_{k,i} \leq x_i \leq {}^2m_{k,i} \\ {}^2\mu_{k,i}(x_i, [\sigma_{k,i}, {}^2m_{k,i}]), & x_i > {}^2m_{k,i} \end{cases} \quad (4)$$

$$\underline{\mu}_{k,i}(x_i) = \begin{cases} {}^2\mu_{k,i}(x_i, [\sigma_{k,i}, {}^2m_{k,i}]), & x_i \leq \frac{{}^1m_{k,i} + {}^2m_{k,i}}{2} \\ {}^1\mu_{k,i}(x_i, [\sigma_{k,i}, {}^1m_{k,i}]), & x_i > \frac{{}^1m_{k,i} + {}^2m_{k,i}}{2} \end{cases} \quad (5)$$

Where $\bar{\mu}_{k,i}$ is upper membership degree and $\underline{\mu}_{k,i}$ is lower membership degree.

Layer 2: This is ruling layer. Each output node represents the lower (\underline{f}^k) and upper (\bar{f}^k) firing strength of a rule:

$$\underline{f}^k = \prod_{i=1}^n \underline{\mu}_{k,i} \quad ; \quad \bar{f}^k = \prod_{i=1}^n \bar{\mu}_{k,i} \quad (6)$$

Layer 3: This is consequent layer.

$$\begin{aligned} \tilde{y}_1 &= \tilde{r}_1 + \tilde{p}_1 x_1 + \tilde{q}_1 x_2 \\ \tilde{y}_2 &= \tilde{r}_2 + \tilde{p}_2 x_1 + \tilde{q}_2 x_2 \\ &\vdots \\ \tilde{y}_k &= \tilde{r}_k + \tilde{p}_k x_1 + \tilde{q}_k x_2 \end{aligned} \quad (7)$$

\tilde{r}_k, \tilde{p}_k and \tilde{q}_k ($k = 1, 2$) are consequent coefficient that they are Gaussian type-1 fuzzy sets. Note that (7) can be extended to \tilde{y}_k ($k = 1, \dots, n$). In this paper for simplicity $k = 2$.

Layer 4: This layer is used for consequent lower-upper firing points [35].

$$\hat{y}_l = \frac{\sum_{k=1}^N \bar{f}^k (m_{r_k} \sigma_{r_k} + m_{p_k} \sigma_{p_k} x_1 + m_{q_k} \sigma_{q_k} x_2) + \sum_{k=N+1}^M \underline{f}^k (m_{r_k} \sigma_{r_k} + m_{p_k} \sigma_{p_k} x_1 + m_{q_k} \sigma_{q_k} x_2)}{\sum_{k=1}^N \bar{f}^k (\sigma_{r_k} + \sigma_{p_k} + \sigma_{q_k}) + \sum_{k=N+1}^M \underline{f}^k (\sigma_{r_k} + \sigma_{p_k} + \sigma_{q_k})}$$

$$\hat{y}_r = \frac{\sum_{k=1}^L \underline{f}^k (m_{r_k} \sigma_{r_k} + m_{p_k} \sigma_{p_k} x_1 + m_{q_k} \sigma_{q_k} x_2) + \sum_{k=L+1}^P \bar{f}^k (m_{r_k} \sigma_{r_k} + m_{p_k} \sigma_{p_k} x_1 + m_{q_k} \sigma_{q_k} x_2)}{\sum_{k=1}^L \underline{f}^k (\sigma_{r_k} + \sigma_{p_k} + \sigma_{q_k}) + \sum_{k=L+1}^P \bar{f}^k (\sigma_{r_k} + \sigma_{p_k} + \sigma_{q_k})} \quad (8)$$

Layer 5: The single node in this layer computes the output.

$$\hat{y} = \frac{\hat{y}_l + \hat{y}_r}{2} \quad (9)$$

Gradient descent with adaptive learning rate backpropagation is used for learning phase [7].

4. Flexible Link Robot Arm

Consider a single-link robotic manipulator coupled to a brushed direct current motor with a no rigid joint. When the joint is modeled as a linear torsional spring, from the Euler-Lagrange equation, the equations of motion for such an electromechanical system can be derived as:

$$\begin{aligned} J_1 \ddot{q}_1 + F_1 \dot{q}_1 + K \left(q_1 - \frac{q_2}{N} \right) + mgd \cos q_1 &= 0 \\ J_2 \ddot{q}_2 + F_2 \dot{q}_2 + \frac{K}{N} \left(q_1 - \frac{q_2}{N} \right) &= K_t i \\ LDi + Ri + K_b \dot{q}_2 &= u \end{aligned} \quad (10)$$

where q_1 and q_2 are the angular positions of the link and the motor shaft, i is the armature current, and u is the armature voltage. The inertias J_1, J_2 , the viscous friction constants F_1, F_2 , the spring constant K , the torque constant K_t , the back-emf constant K_b , the armature resistance R and inductance L , the link mass M , the position of the link's center of gravity d , the gear ratio N and the acceleration of gravity g can all be unknown. A flexible link robot arm is shown in Fig. 4.

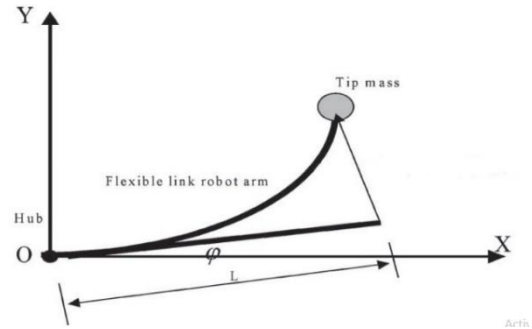

Fig. 4. Configuration of flexible-link robot arm.

5. Simulation Results

In this section, a flexible link robot arm is controlled using ANFIS2. The structure of the robot arm and ANFIS2 based controller is shown in Fig 5. Where the reference signal (desired angle in here) is applied to system then the error between reference signal and the output of robot system (angle of link in here) is calculated. This error must be minimized, so ANFIS2 is adapted to minimize the error.

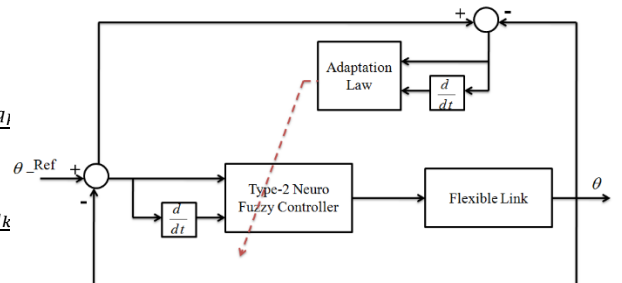

Fig. 5. The structure of the robot arm and ANFIS2 based controller.

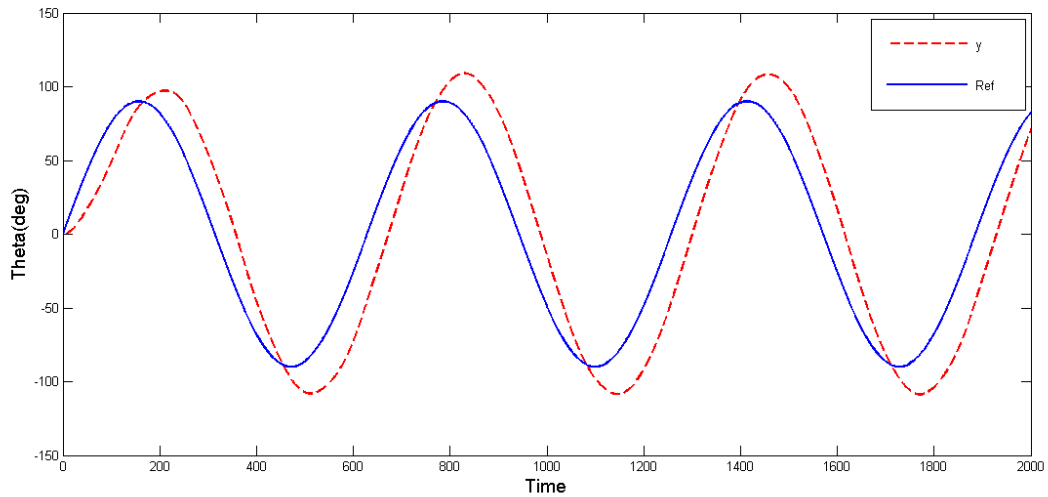

Fig. 6. ANFIS2 based controller with sine angle reference.

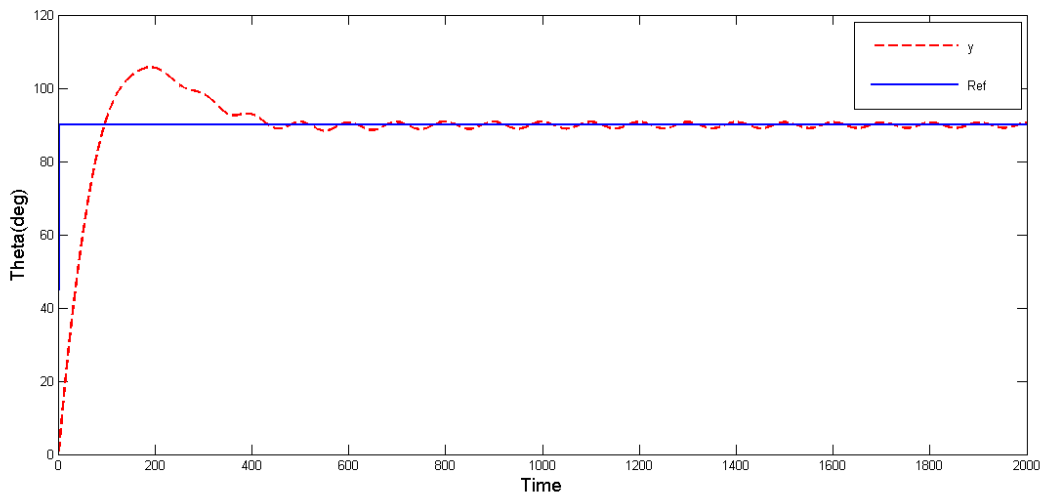

Fig. 7. ANFIS2 based controller with step angle reference.

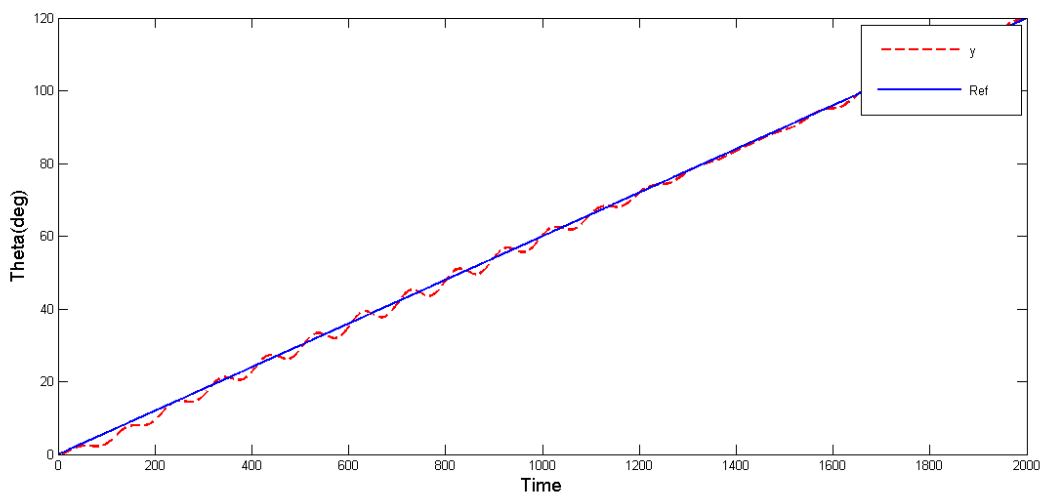

Fig. 8. ANFIS2 based controller with ramp angle reference.

In order to illustrate the effectiveness of the proposed results, the simulation will be conducted to control system, where $J_1 = 1.625 \text{ kg m}^2$, $J_2 = 1.625 \text{ kgm}^2$, $R = 0.5$ • , $K_t = 0.9 \text{ N m/A}$, $K = 0.5868$, $K_b = 0.9 \text{ N m/A}$, $M =$

4.34 kg , $L = 25.0 \times 10^{-3} \text{ H}$, $g = 9.8 \text{ N/kg}$, $F_1 = 1.625 \times 10^{-2} \text{ N m s/rad}$, $F_2 = 1.625 \times 10^{-2} \text{ N m s/rad}$, $N = 2$, $d = 0.5 \text{ m}$.

The performance of ANFIS2 with sine angle reference is shown in fig. 6 and the performance of ANFIS2 with step angle reference is shown in fig. 7. Also, figures 5-8 show that adaptive inverse control based on ANFIS2 is suitable and robust strategy to control of a flexible link robot arm.

6. Conclusion

In this paper, a novel ANFIS2 was proposed for identification of nonlinear dynamical systems. The proposed ANFIS2 is based on interval Gaussian type-2 fuzzy sets in the antecedent part and Gaussian type-1 fuzzy sets as coefficients of linear combination of input variables in the consequent part that it helps to improve modeling of highly nonlinear systems. Adaptive learning rate helps to prevent the ANFIS2 from trapping into a local minimum and it helps to fast convergence of training algorithm. The test results show the importance and necessity of ANFIS2 to modeling the inverse of uncertain systems and control it.

References

- [1] J. Tavooosi, A. A. Suratgar, M. B. Menhaj, Nonlinear system identification based on a self-organizing type-2 fuzzy RBFN, *Engineering Applications of Artificial Intelligence* 54 (2016), 26-38.
- [2] Huang H, Shirkhani M, Tavooosi J, Mahmoud O. A new intelligent dynamic control method for a class of stochastic nonlinear systems. *Mathematics*. 2022 Apr 22;10(9):1406.
- [3] Guo X, Shirkhani M, Ahmed EM. Machine-Learning-Based improved smith predictive control for MIMO processes. *Mathematics*. 2022 Oct 9;10(19):3696.
- [4] Aazami R, Heydari O, Tavooosi J, Shirkhani M, Mohammadzadeh A, Mosavi A. Optimal Control of an Energy-Storage System in a Microgrid for Reducing Wind-Power Fluctuations. *Sustainability*. 2022 May 19;14(10):6183.
- [5] Iranmehr H, Aazami R, Tavooosi J, Shirkhani M, Azizi AR, Mohammadzadeh A, Mosavi AH, Guo W. Modeling the price of emergency power transmission lines in the reserve market due to the influence of renewable energies. *Frontiers in Energy Research*. 2022 Jan 13;9:792418.
- [6] J. Tavooosi, M. Alaei, B. Jahani, Temperature Control of Water Bath by using Neuro-Fuzzy Controller, 5th Symposium on Advance in Science & Technology, 2011.
- [7] Danyali S, Aghaei O, Shirkhani M, Aazami R, Tavooosi J, Mohammadzadeh A, Mosavi A. A New Model Predictive Control Method for Buck-Boost Inverter-Based Photovoltaic Systems. *Sustainability*. 2022 Sep 19;14(18):11731.
- [8] J. Tavooosi, M. Alaei, B. Jahani, M.A. Daneshwar, A novel intelligent control system design for water bath temperature control, *Australian Journal of Basic and Applied Sciences* 5 (12) 1879-1885, 2011.
- [9] Tavooosi J, Shirkhani M, Azizi A. Control engineering solutions during epidemics: A review. *International Journal of Modelling, Identification and Control*. 2021;39(2):97-106.
- [10] G.C. Calafiore, A subsystems characterization of the zero modes for flexible mechanical structures, in: *Proceedings of 36th IEEE Conference On Decision and Control, San Diego, CA, 1997*, pp. 1375–1380.
- [11] Tavooosi J, Shirkhani M, Azizi A, Din SU, Mohammadzadeh A, Mobayen S. A hybrid approach for fault location in power distributed networks: Impedance-based and machine learning technique. *Electric Power Systems Research*. 2022 Sep 1;210:108073.
- [12] S. Huang, M. Chen, Constructing optimized interval type-2 TSK neuro-fuzzy systems with noise reduction property by quantum inspired BFA, *Neurocomputing* 173 (2015) 1839-1850.
- [13] J. Tavooosi, A. A. Suratgar, M. B. Menhaj, Stable ANFIS2 for Nonlinear System Identification, *Neurocomputing* 182 (2016) 235–246.
- [14] Monjezi V, Trivedi A, Tan G, Tizpaz-Niari S. Information-Theoretic Testing and Debugging of Fairness Defects in Deep Neural Networks. *arXiv preprint arXiv:2304.04199*. 2023 Apr 9.
- [15] Tavooosi J, Shirkhani M, Abdali A, Mohammadzadeh A, Nazari M, Mobayen S, Asad JH, Bartoszewicz A. A new general type-2 fuzzy predictive scheme for PID tuning. *Applied Sciences*. 2021 Nov 5;11(21):10392.
- [16] R. Shahnazi, Observer-based adaptive interval type-2 fuzzy control of uncertain MIMO nonlinear systems with unknown asymmetric saturation actuators, *Neurocomputing* 171 (2016) 1053-1065.
- [17] S.I. Han, J.M. Lee, Recurrent fuzzy neural network backstepping control for the prescribed output tracking performance of nonlinear dynamic systems, *ISA Transactions* 53 (2014) 33–43.
- [18] J. Tavooosi, MA Badamchizadeh, S Ghaemi, Adaptive Inverse Control of Nonlinear Dynamical System Using Type-2 Fuzzy Neural Networks, *Journal of Control* 5 (2) (2011).
- [19] YP Asad, A Shamsi, H Ivani, J Tavooosi, Adaptive Intelligent INverse Control of Nonlinear Systems with Regard to Sensor Noise and Parameter Uncertainty (Magnetic Ball Levitation System Case Study), *International Journal on Smart Sensing and Intelligent Systems* 9 (1) 148-169.
- [20] T.C. Lin, C.H. Kuo, V.E. Balas, Real-time fuzzy system identification using uncertainty bounds, *Neurocomputing* 125 (2014) 195–216.
- [21] J. Soto, P. Melin, Genetic Optimization of Type-2 Fuzzy Integrators in Ensembles of ANFIS Models for Time Series Prediction, *Recent Advances on Hybrid Approaches for Designing Intelligent Systems Studies in Computational Intelligence* 547 (2014) 79–97.
- [22] H.M. Vaghefi, M.R. Sandgani, M. A. Shoorehdeli, Interval Type-2 Adaptive Network-based Fuzzy Inference System (ANFIS) with Type-2 non-singleton fuzzification, *13th Iranian Conference on Fuzzy Systems* (2013) 1–6.
- [23] G.M. Mendez, D.L.A Hernandez, Interval Type-2 ANFIS. In: *Innovations in Hybrid Intelligent Systems*, Springer, Heidelberg (2007) 64–71.
- [24] S. Bhattacharyya, D. Basu, A. Konar, D.N. Tibarewala, Interval type-2 fuzzy logic based multiclass ANFIS algorithm for real-time EEG based movement control of a robot arm, *Robotics and Autonomous Systems* 68 (2015) 104–115.

- [25] J. Tavoosi, M.A. Badamchizadeh, A Class of Type-2 Fuzzy Neural Networks for Nonlinear Dynamical System Identification, *Neural Computing & Application* 23 (3) (2013) 707–717.
- [26] J Tavoosi, AA Suratgar, MB Menhaj, Stability analysis of recurrent type-2 TSK fuzzy systems with nonlinear consequent part, *Neural Computing and Applications* (2015) 1-10.
- [27] F. Jahangiri, A. Doustmohammadi, M.B. Menhaj, An adaptive wavelet differential neural networks based identifier and its stability analysis, *Neurocomputing* 77(2012)12–19.
- [28] J Tavoosi, AA Suratgar, MB Menhaj, Stability Analysis of a Class of MIMO Recurrent Type-2 Fuzzy Systems, *International Journal of Fuzzy Systems* (2016) 1-14.
- [29] J. Tavoosi, A. Shamsi Jokandan, M. A. Daneshwar, A new method for position control of a 2-DOF robot arm using neuro-fuzzy controller, *Indian Journal of Science and Technology* 5 (3) (2012) 2253-2257.
- [30] M.B.B. Sharifian, A. Mirlo, J. Tavoosi, M. Sabahi, Self-adaptive RBF neural network PID controller in linear elevator, *International Conference on Electrical Machines and Systems (ICEMS)*, 2011.
- [31] Jafar Tavoosi, Majid Alaei, Behrouz Jahani, Neuro – Fuzzy Controller for Position Control of Robot Arm, *5th Symposium on Advances in Science and Technology (5thsastech)*, 2011.
- [32] M.B.B Sharifian Jafar Tavoosi, Ahad Mirloo, PMSM Position and Speed Estimation by Moving Horizon Estimation (MHE), *ICEE19_207*, 2011.
- [33] T. Dereli, A. Baykasoglu, K. Altun, A. Durmusoglu, I.B. Turksen, Industrial applications of type-2 fuzzy sets and systems: A concise review, *Computers in Industry* 62 (2011) 125–137.
- [34] J.R. Castro, O. Castillo, L.G. Martínez, an Interval Type-2 Fuzzy Logic Toolbox for Control Applications, *IEEE International Conference on Fuzzy Systems*, London (2007) 1–6.
- [35] C.J. Chen, S.M. Yang, Z.C. Wung, System Identification by Neuro-Fuzzy Model with Sugeno and Mamdani Fuzzy Rules, *Journal of Aeronautics, Astronautics and Aviation, Series A* 41 (4) (2009) 263 – 270.